

MATRASUR COMPOSITES

COMPOSITE TRIMMING ROBOT
ROBOT D'USINAGE DES COMPOSITES



Divide trimming cycle times by 4

Réduisez les temps d'usinage par 4

Obtain high precision and perfect process repetitiveness

Obtenez une grande précision et une répétitivité parfaite

Stop operator exposure to trimming dust and eliminate the risk of accidents

Stoppez l'exposition des opérateurs aux poussières et les risques d'accidents

Concentrate trimming operations in one area

Concentrez l'ensemble de l'usinage sur un poste



Your step by step guide to installing an automated composite trimming solution in your production workshop

Feuille de route étape par étape pour intégrer dans votre atelier de production un concept robotisé approprié à l'usinage de vos pièces composites



Mould support cart
Conformateur



8-axes robot
wide motion range
Robot 8 axes grand
rayon d'action



Electric spindle
Broche électrique



Pneumatic spindle
Broche pneumatique



Mould support cart
positioning system
Indexage
chariot
support
conformateur

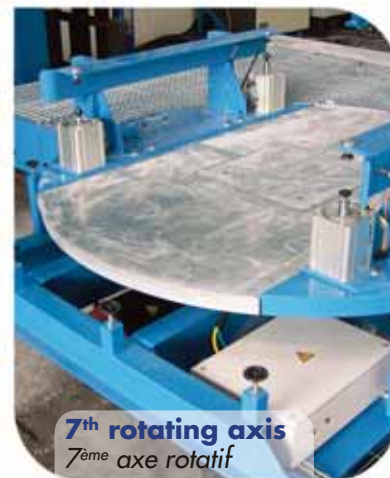

7th rotating axis
7^{eme} axe rotatif

ANALYSIS OF THE PARTS TO BE TRIMMED

EXPERTISE DES PIÈCES À USINER

MATRASUR
COMPOSITES

Part dimensions
Dimensions pièces



Daily quantities
Quantitatifs journaliers

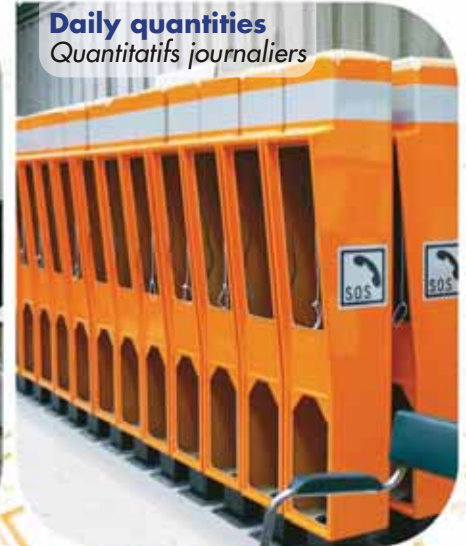

Materials
Matériaux

Trimming process
Type d'usinage

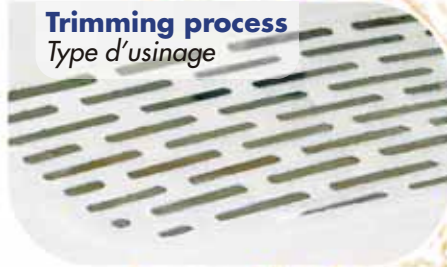

Thickness
Epaisseur

Part depth
Emboutis pièces



CHOICE OF THE MOULD SUPPORT CART AND POSITIONING SYSTEM

CHOIX DES CONFORMATEURS ET INDEXAGES

Mould support cart for large parts
Conformateur grandes pièces



Universal mould support cart
Conformateur universel

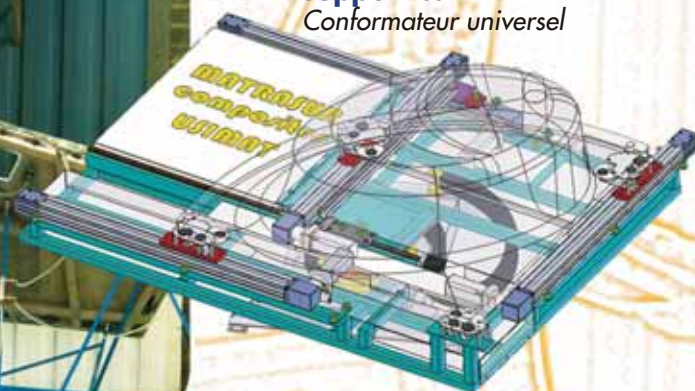

Manual mould positioning system
Indexage manuel

Automatic mould positioning system
Indexage automatique chariot conformateur

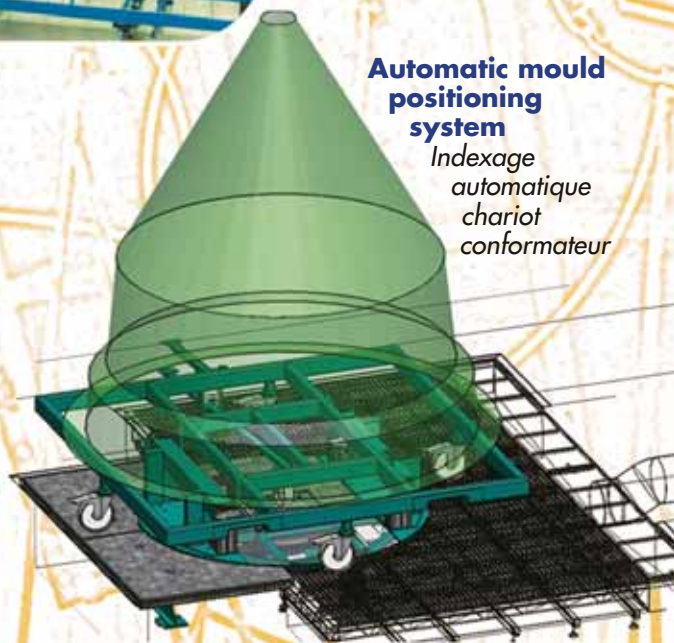

ROBOT SELECTION - CHOIX DU ROBOT



Robot with a 7th linear axis
Robot 7 axes linéaire



6-axes robot
Robot 6 axes



8-axes robot
Robot 8 axes

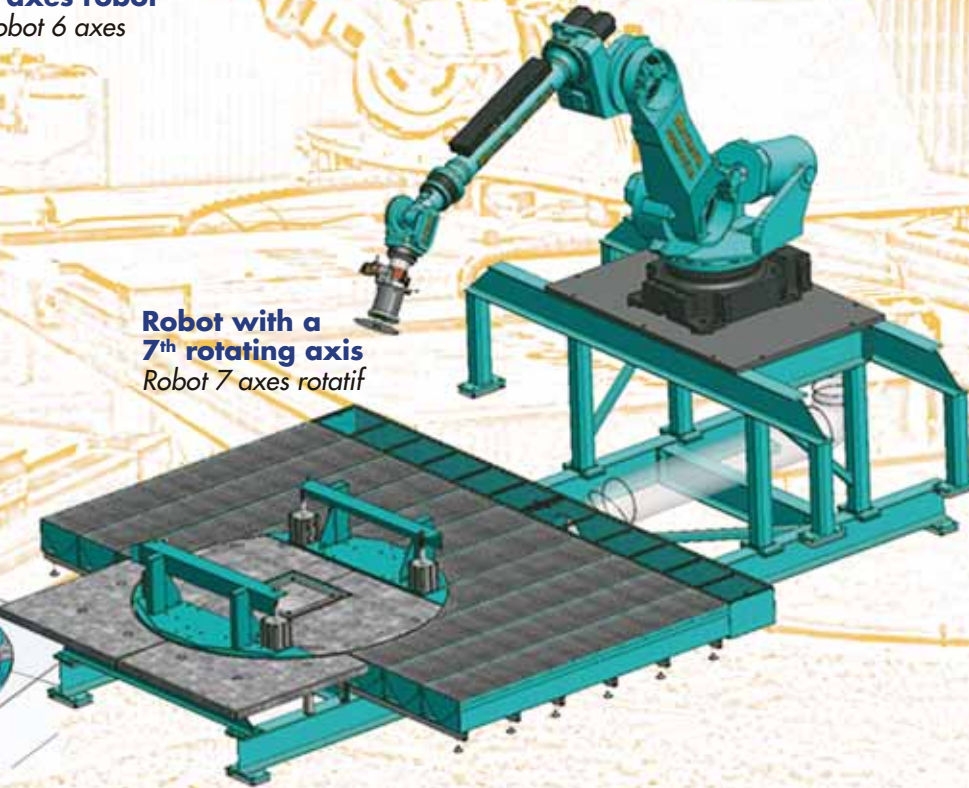

Robot with a 7th rotating axis
Robot 7 axes rotatif

SPINDLE AND TOOL SELECTION

CHOIX DE LA BROCHE ET DES OUTILS

STEP IV
ETAPE IV

Pneumatic spindle and tool rack

Broche pneumatique avec rack outils



Pneumatic spindle with diamond disc

Broche pneumatique avec disque



Electric spindle with drill

Broche électrique avec fraise



Electric spindle with tool rack

Broche électrique avec rack outils



CHOICE OF THE TRIMMING CONCEPT

CHOIX DU CONCEPT D'USINAGE

"Low Cost" concept
Concept "Low cost"

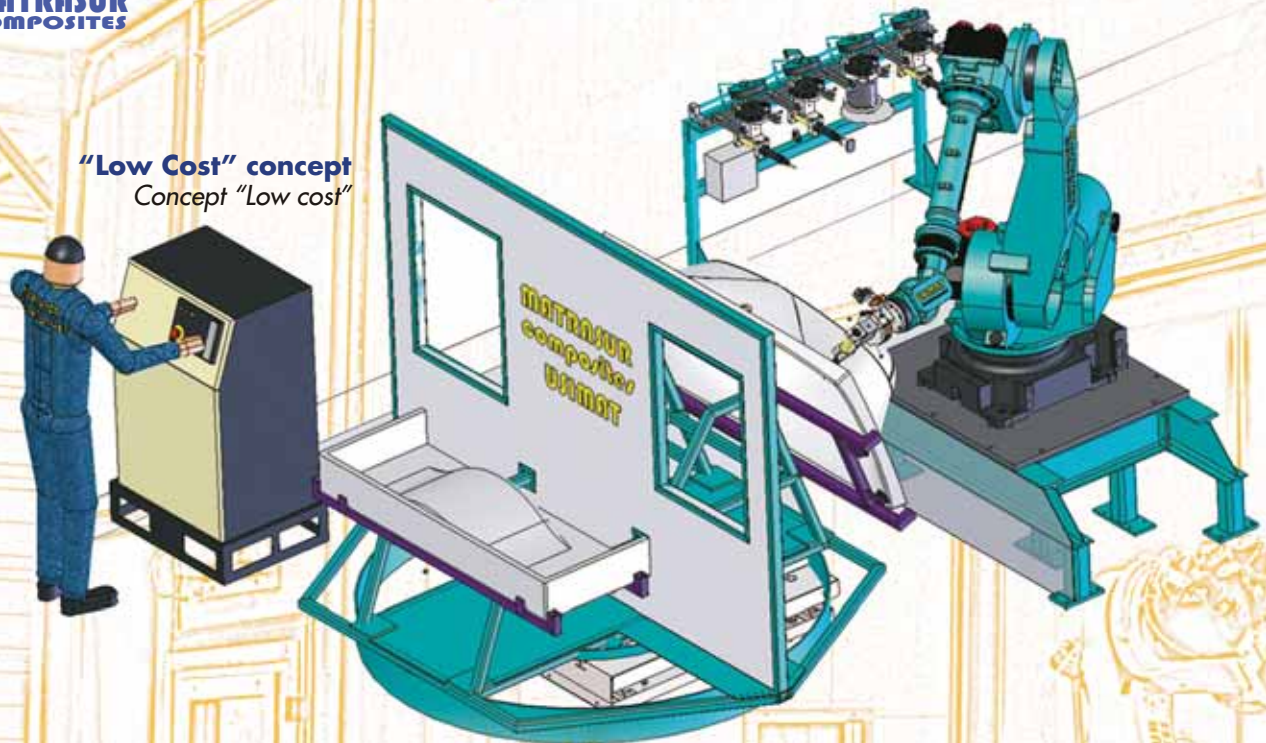

Tailored concept
Concept sur mesure

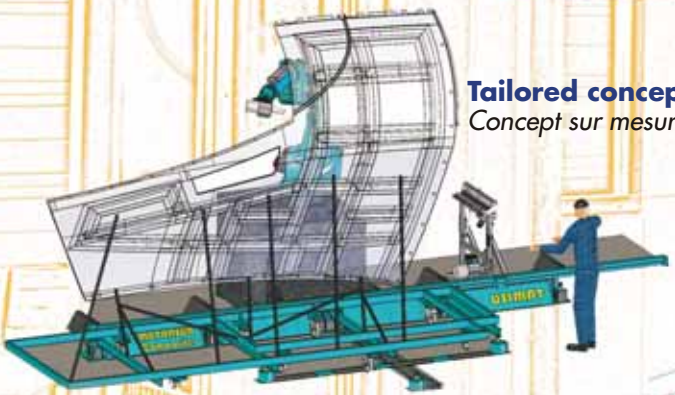

Standard concept
Concept standard

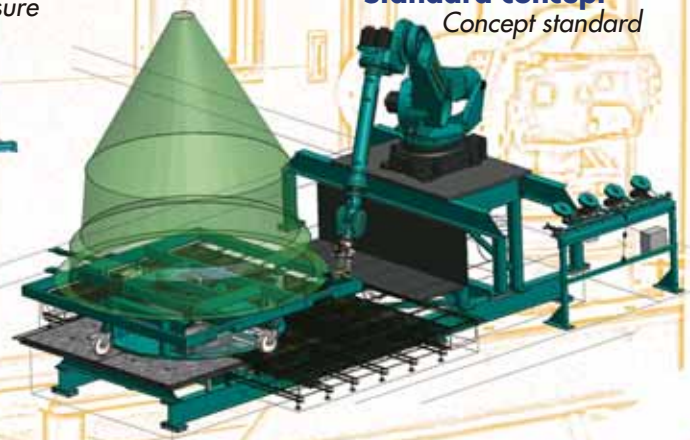

CHOICE OF THE CABIN AND DUST EXTRACTION SYSTEM

CHOIX DE LA CABINE ET DU TRAITEMENT DES POUSSIÈRES

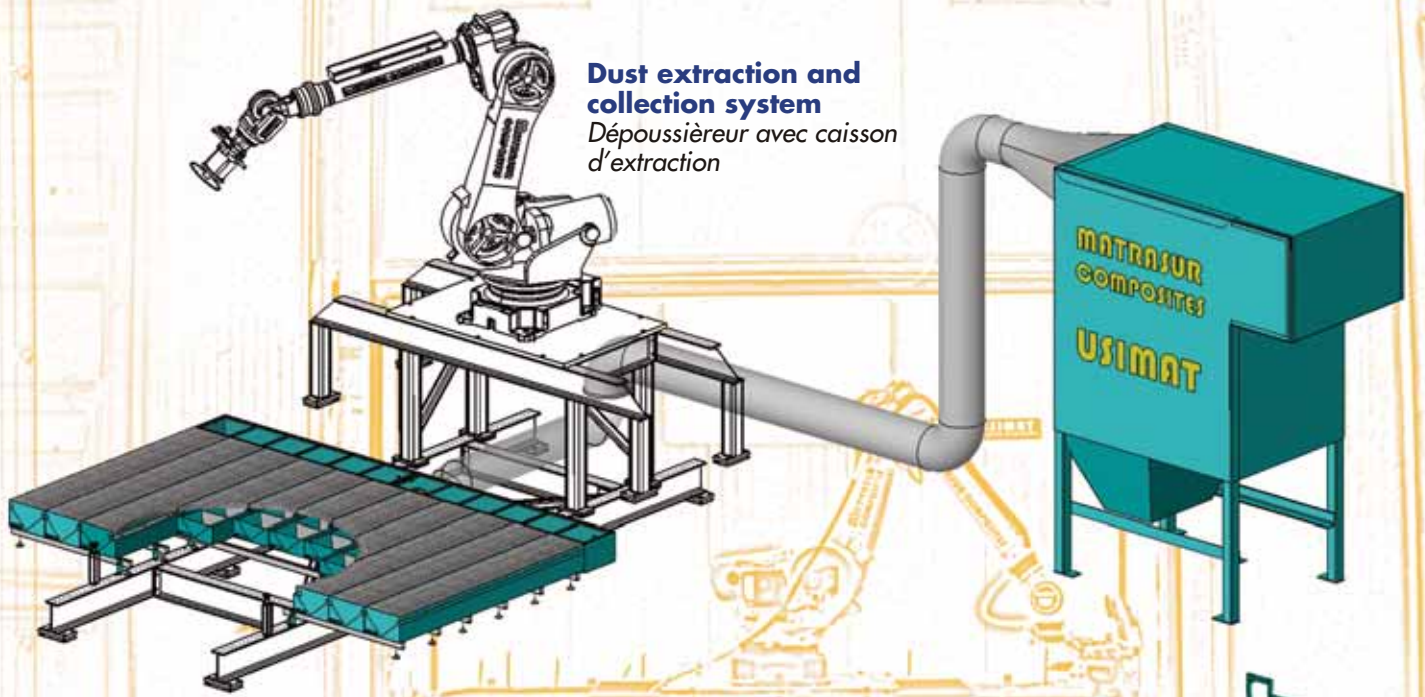

Dust extraction and collection system
Dépoussiéreur avec caisson d'extraction

Standard cabin
Cabine standard

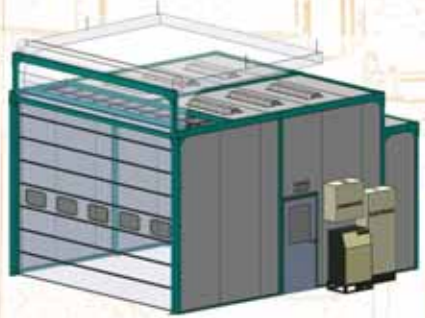

"Low cost" cabin
Cabine "Low cost"



Tailored cabin
Cabine sur mesure



STEP VII
ETAPE VII

MATRASUR
COMPOSITES

3D LAY-OUT OF THE SELECTED TRIMMING CONCEPT IN YOUR WORKSHOP AND QUOTATION

INTÉGRATION DU CONCEPT D'USINAGE RETENU
DANS VOTRE ATELIER EN 3D ET DEVIS CHIFFRÉ

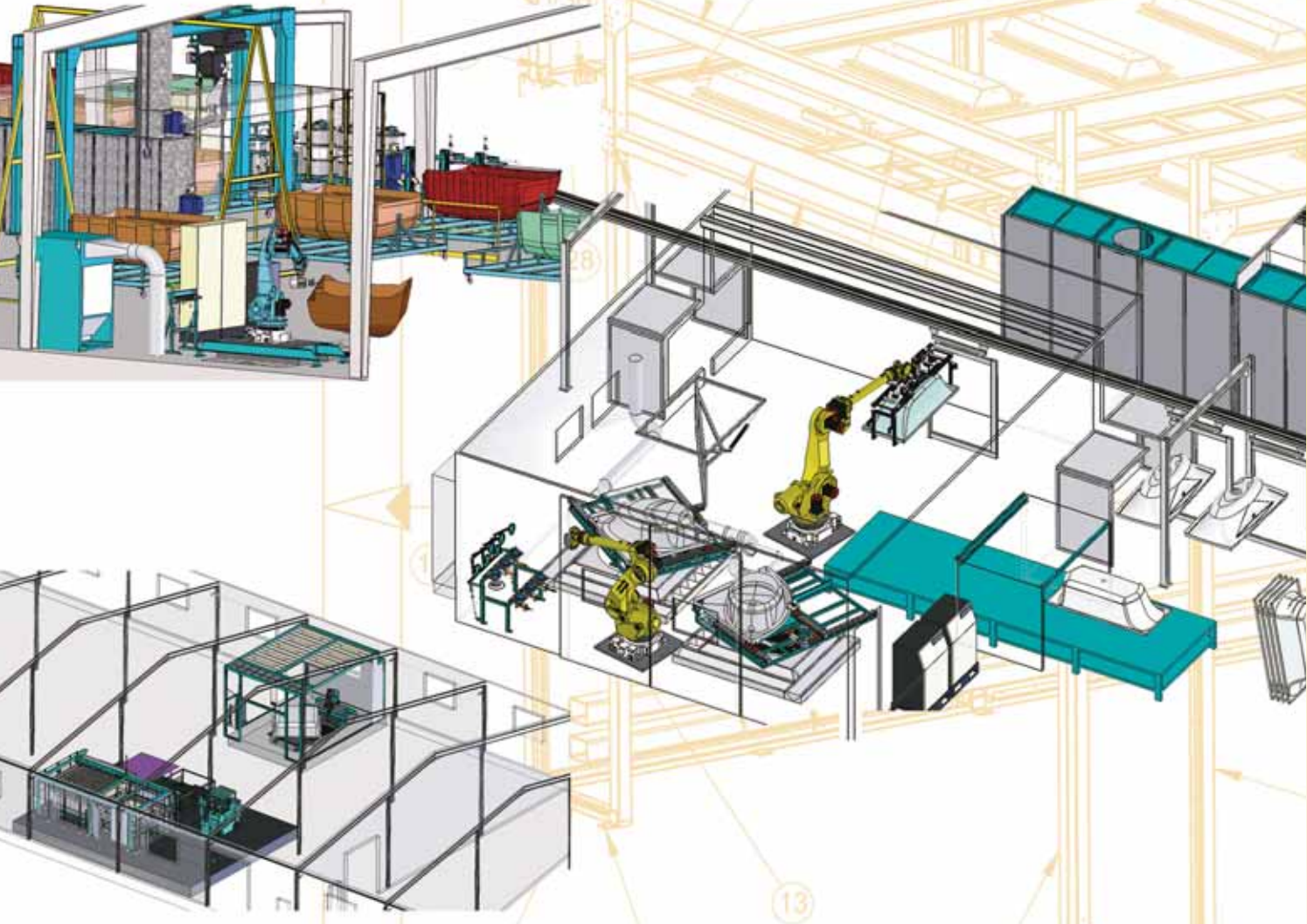

EQUIPMENT ASSEMBLY, COMMISSIONING AND TRAINING

MONTAGE, MISE EN ROUTE ET FORMATION

STEP VIII
ETAPE VIII

Operators' training
Formation des opérateurs



Assembly
Montage



Commissioning
Mise en route



Management team training
Formation encadrement



AFTER-SALES SERVICE

SERVICE APRÈS VENTE



Remote assistance
Télmaintenance



Part programming
Programmation pièce



Maintenance
Maintenance



Mould support manufacture
Fabrication conformateur

MATRASUR COMPOSITES' RESOURCES

LES MOYENS DE MATRASUR COMPOSITES



1 000 m² assembly workshop

Atelier d'assemblage de 1 000 m²

400 m² robot demonstration hall

Atelier de démonstration robotisé de 400 m²

500 m² engineering office including automation, robotics and professional training services

Bureau d'études, automatisme, robotique, formation continue de 500 m²

400 m² sales and administration office

Bureau commercial et administratif de 400 m²



MATRASUR COMPOSITES' STRENGTHS

LA FORCE DE MATRASUR COMPOSITES



Excellent knowledge of composite materials

Connaissance approfondie des matériaux composites

Experience in the automation of composite production since 1972

Expérience depuis 1972 dans l'industrialisation des composites

Ability to carry out 100% of your automation project

Prise en charge d'un projet d'usinage à 100 %

Local after-sales service

Service après-vente de proximité

SUCCESS STORIES

MATRASUR Composites has won the trust of many small and medium sized companies in the industrialization of their production processes with the help of robotic solutions. A positive return on investment is obtained very quickly by a significant reduction of trimming cycle times, the high degree of precision obtained and the process repetitiveness. These advantages have enabled

our clients to become more competitive and win market share. Beyond the economical advantage brought by the automation, the introduction of robotics can help to put you in a leading position with regards to Health and Safety, and environmental legislation. Contact us to find out how robotics can bring increased security and competitiveness to your business.

De nombreuses petites et moyennes entreprises ont déjà fait confiance à MATRASUR Composites et se sont industrialisées grâce à la robotisation. La réduction très importante des temps d'usinage, le haut niveau de précision et de répétitivité obtenu ont permis un retour sur investissement très rapide. Nos clients ont pu retrouver leurs marges

face à la concurrence. Au-delà de tous les avantages économiques de l'industrialisation, la robotisation permet de positionner l'entreprise face aux exigences de toutes les législations du travail et des contraintes environnementales. Aujourd'hui la pérennité de ces entreprises est envisagée avec sérénité.



Before
Avant



The result
La réalisation

The project
Le projet

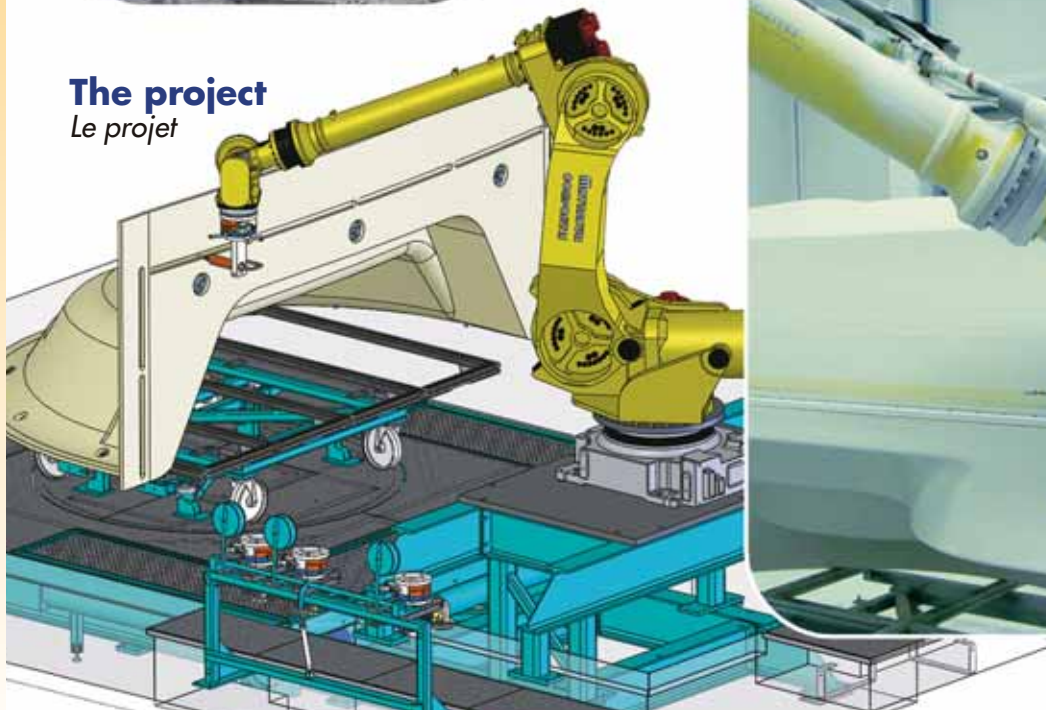

MATRASUR COMPOSITES

European equipment constructor
of robotic production lines for
the composites industry



Matrasur Composites' site in Marcoussis



Matrasur Composites
is in the outskirts of Paris,
France



Matrasur Composites
is located 25 km south-west
from Paris

*Constructeur européen en
équipements et lignes de
production robotisées pour
l'industrie des composites*



Access to our production
site in Marcoussis

C.D.3 Hameau de Beauvert - 91460 Marcoussis - France
Tel. : +33 1 69 801 801 - Fax : +33 1 69 809 809
www.matrasurcomposites.com - info@matrasurcomposites.com